

**SELECTED FEATURES**

**NOTES**

1. MATERIAL: ALUMINUM
2. FINISH: MILL
3. LOADING: 300 PSF
4. 316 SS NUTS & BOLTS
5. APPROX HATCH WT: 74.50 LBS

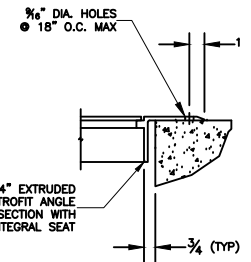
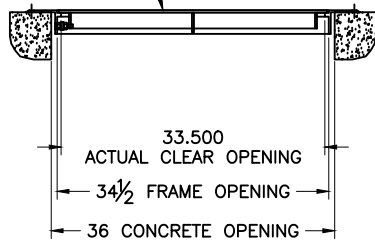
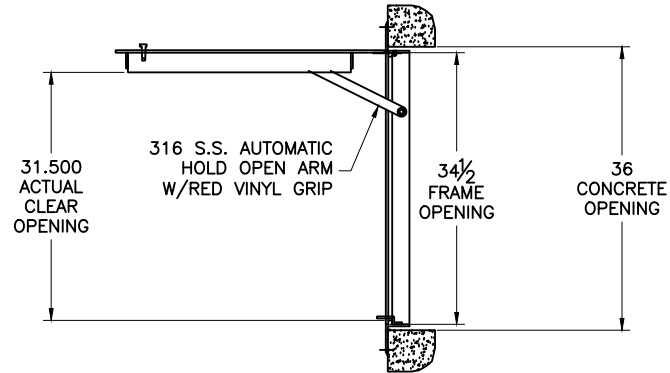
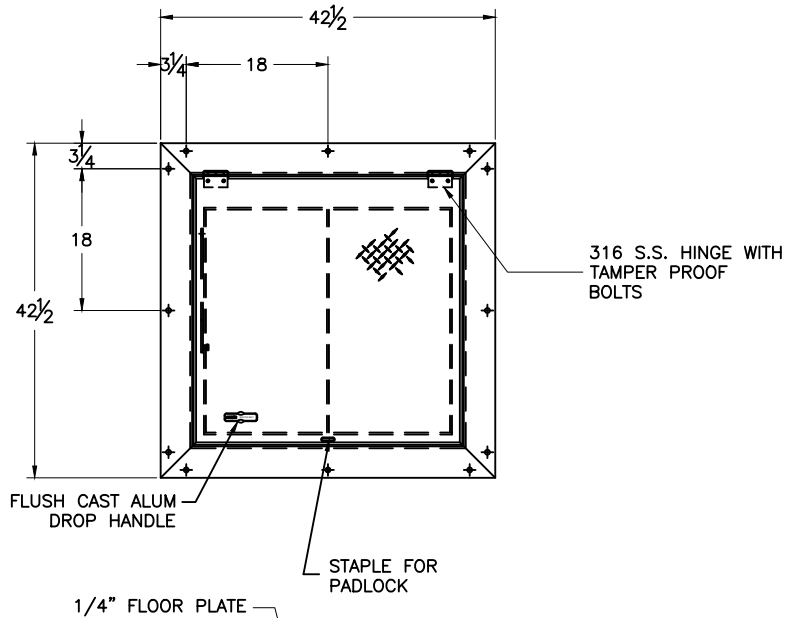

**FRAME DETAIL**

**NOTE:**  
AS AN AUTOMATED DRAWING, THE DESIGN HAS NOT BEEN REVIEWED BY USFF ENGINEERING AND IS THEREFORE TO BE USED FOR REFERENCE ONLY. USFF RESERVES THE RIGHT TO ADJUST DIMENSIONS TO INSURE ADHERENCE TO CUSTOMER REQUIREMENTS AND PROPER OPERATION OF THE PRODUCT.

THIS DOCUMENT IS THE PROPERTY OF ACUDOR PRODUCTS, INC AND CONTAINS PROPRIETARY INFORMATION. IT SHALL NOT BE MODIFIED, COPIED, FURNISHED NOR DISTRIBUTED (IN WHOLE OR IN PART) WITHOUT PROPER AUTHORIZATION OF ACUDOR PRODUCTS, INC.

INTERPRET DIMENSIONS AND TOLERANCES PER ASME Y14.5M

BREAK ALL SHARP CORNERS & EDGES TO 0.01

TOLERANCES UNLESS OTHERWISE SPECIFIED FRACTIONAL

INCHES = ± 1/16  
1/16 = ± 1/32  
1/32 = ± 1/64

COPYRIGHT © 2016  
ALL RIGHTS RESERVED

**ACUDOR PRODUCTS**

**RETROFIT HATCH FA-300 ALUM  
FOR 36 X 36 EXISTING OPENING**

DWN. BY: BOB	SCALE: 1:24	SHEET: 1 OF 1	DATE: 02/09/18
CHK. BY: BOB	DWG # 1000093181	SHEET SIZE: A	REV: 0